

DF Assembly

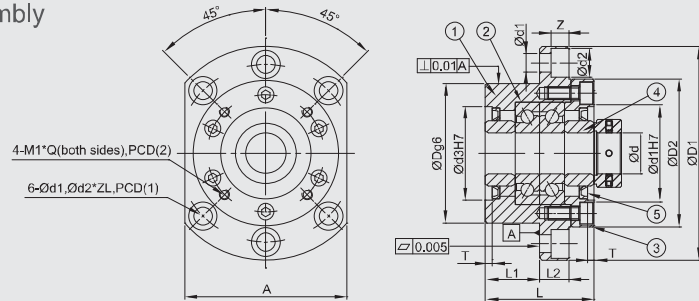

DFD Assembly

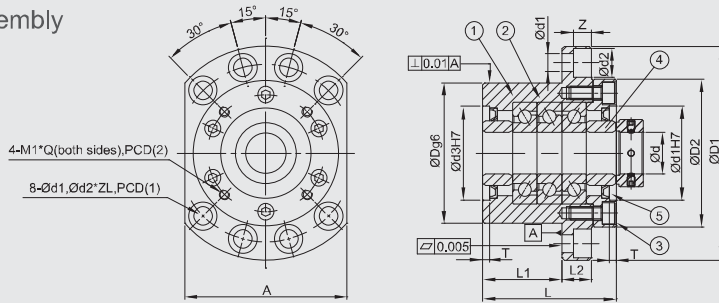

Specification

Model No.		Dimensions													
Black Dyed	Ni Plating	Ød	ØD	ØD1	ØD2	Ød3	L	L1	L2	A	PCD (1)	PCD (2)	Ød1	Ød2	Z
GWFF17B-DF	GWFF17N-DF	17	70	106	72	45	60	32	15	80	88	58	8.7	14	8.5
GWFF20B-DF	GWFF20N-DF	20	70	106	72	45	60	32	15	80	88	58	8.7	14	8.5
GWFF25B-DF	GWFF25N-DF	25	85	130	90	57	66	33	18	100	110	70	10.7	17.5	11
GWFF25B-DFD	GWFF25N-DFD	25	85	130	90	57	81	48	18	100	110	70	10.7	17.5	11
GWFF30B-DF	GWFF30N-DF	30	85	130	90	57	66	33	18	100	110	70	10.7	17.5	11
GWFF30B-DFD	GWFF30N-DFD	30	85	130	90	57	81	48	18	100	110	70	10.7	17.5	11
GWFF35B-DF	GWFF35N-DF	35	95	142	102	69	66	33	18	106	121	80	10.7	17.5	11
GWFF35B-DFD	GWFF35N-DFD	35	95	142	102	69	81	48	18	106	121	80	10.7	17.5	11
GWFF40B-DF	GWFF40N-DF	40	95	142	102	69	66	33	18	106	121	80	10.7	17.5	11
GWFF40B-DFD	GWFF40N-DFD	40	95	142	102	69	81	48	18	106	121	80	10.7	17.5	11

Ordering Example	GWFF	20	N	DFD	J
	Model No.	Shaft Dia.	Surface finish	Bearing Assembly	Bearing category

GWFF-B-DF



GWFF-N-DF



Components

No.	Parts	Material	Q'ty
①	Main housing	S50C	1
②	Bearing	SUJ2	1 pair
③	Cover	S50C	1
④	Space ring	S50C	2
⑤	Seal (<Ø8 one seal only)	NBR	2
⑥	Lucknut	S50C	1

- ① ② ③ are in one unit. No disassemble for accuracy concern.
- Bearing filled with proper lithium soap lubricant and sealed.

Recommended processing dimensions of shaft

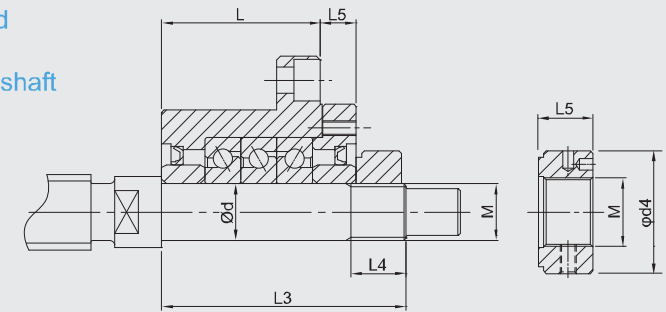

Unit : mm

T	M1	Q	Basic dynamic load(C) (N)	Limited load (N)	Pre-load (N)	Axial rigidity (N/um)	Start torque (N·cm)	Shaft dimensions			Lock nut			Weight (kg)
								Ød	L3	L4	M	Ød4	L5	
3	M5	10	21900	26600	2150	750	14	17	81	23	M17*P1.0	37	18	1.9
3	M5	10	21900	26600	2150	750	14	20	81	23	M20*P1.0	40	18	1.9
4	M6	14	28500	40500	3150	1000	23	25	89	26	M25*P1.5	45	20	3.1
4	M6	14	46500	81500	4300	1470	31	25	104	26	M25*P1.5	45	20	3.4
4	M6	14	29200	43000	3350	1030	24	30	89	26	M30*P1.5	50	20	3.0
4	M6	14	47500	86000	4500	1520	33	30	104	26	M30*P1.5	50	20	3.3
4	M6	14	31000	50000	3800	1180	28	35	92	30	M35*P1.5	55	22	3.4
4	M6	14	50500	100000	5200	1710	37	35	107	30	M35*P1.5	55	22	4.3
4	M6	14	31500	52000	3900	1230	28	40	92	30	M40*P1.5	60	22	3.6
4	M6	14	51500	104000	5300	1810	38	40	107	30	M40*P1.5	60	22	4.2