

Model No.	Parts no. ①	
	Material	Surface Finish
GFF □□ - □	S50C	Black Dyed
GFF □□ - □		Ni-Plating

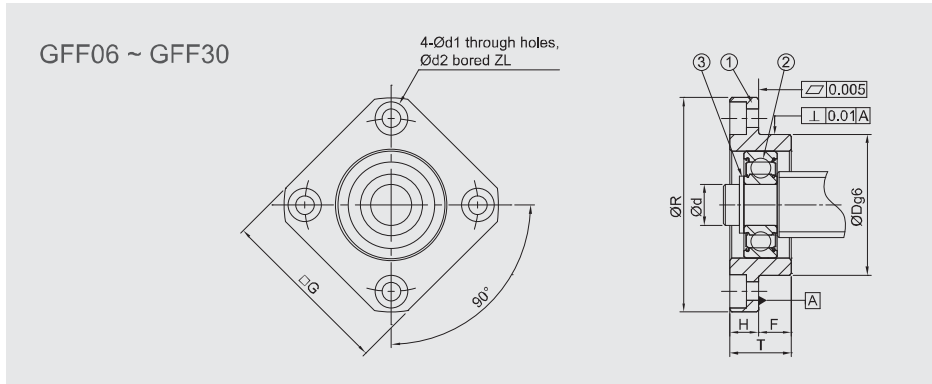

Specification

Standard Type	Dimensions									
	Ød	ØR	□G	T	H	F	ØDg6	PCD	Ød1	Ød2
GFF06-□	6	36	28	10	6	4	22 <sup>+0.007</sup> / <sub>-0.005</sub>	28	3.4	6
GFF10-□	8	43	35	12	7	5	28 <sup>+0.007</sup> / <sub>-0.005</sub>	35	3.4	6
GFF12-□	10	52	42	15	7	8	34 <sup>+0.008</sup> / <sub>-0.005</sub>	42	4.2	8
GFF15-□	15	63	52	17	9	8	40 <sup>+0.009</sup> / <sub>-0.005</sub>	50	5.2	9.5
GFF17-□	17	77	61	20	11	9	50 <sup>+0.009</sup> / <sub>-0.005</sub>	62	6.6	11
GFF20-□	20	85	68	20	11	9	57 <sup>+0.010</sup> / <sub>-0.009</sub>	70	6.3	11
GFF25-□	25	98	79	24	14	10	63 <sup>+0.010</sup> / <sub>-0.009</sub>	80	8.7	14
GFF30-□	30	117	93	27	18	9	75 <sup>+0.010</sup> / <sub>-0.009</sub>	95	10.7	17.5

Ordering Example	GFF	10	N	J
	Model No.	Shaft Dia.	Surface finish	Bearing category



Components

No.	Parts	Material	Q'ty
①	Main housing	S50C	1
②	Bearing	SUJ2	1
③	Snap ring	SWB	1

- Bearing filled with proper lithium soap lubricant maintenance free.
- Bearing with two steel covers in black dyed.
- Bearing with two touch-type plastic covers in Ni-plating.

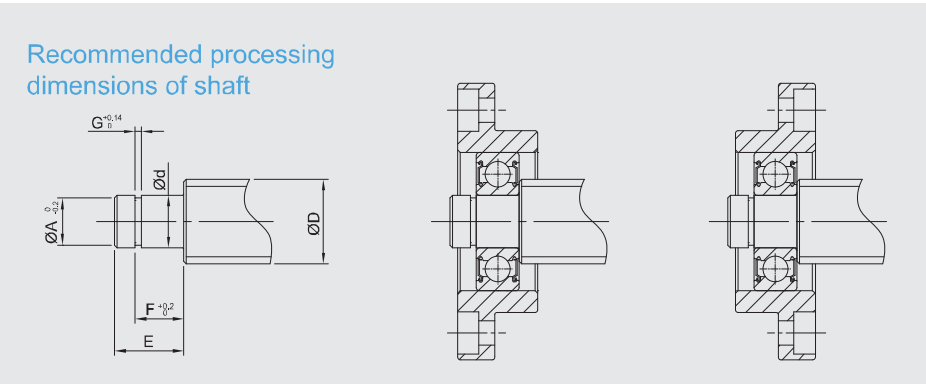

Unit : mm

Z	Recommended processing dimensions of shaft						Snap ring
	Ball Screw Shaft O. D.	Shaft End Diameter	Groove sizes machined for snap ring				
	ØD	Ød	ØA	E	F	G	
3.3	8	6 <sup>+0.005</sup> / <sub>-0.012</sub>	5.7	9	6.8	0.8	S 06
3.3	12 / 14 / 15	8 <sup>+0.005</sup> / <sub>-0.012</sub>	7.6	10	7.9	0.9	S 08
4.4	14 / 15 / 16	10 <sup>+0.005</sup> / <sub>-0.017</sub>	9.6	11	9.15	1.15	S 10
5.4	18 / 20	15 <sup>+0.005</sup> / <sub>-0.014</sub>	14.3	13	10.15	1.15	S 15
8.6	20 / 25	17 <sup>+0.005</sup> / <sub>-0.014</sub>	16.2	16	13.15	1.15	S 17
6.5	25 / 28 / 30	20 <sup>+0.005</sup> / <sub>-0.014</sub>	19	19	15.35	1.35	S 20
8.6	30 / 32 / 36	25 <sup>+0.005</sup> / <sub>-0.011</sub>	23.9	20	16.35	1.35	S 25
10.8	36 / 40	30 <sup>+0.005</sup> / <sub>-0.015</sub>	28.6	21	17.75	1.75	S 30

• Fixed Side spec please refer to P.28~P.29