

Model No.	Parts no. ①	
	Material	Surface Finish
GEF □□ - SB	S50C	Black Dyed
GEF □□ - SN		Ni-Plating

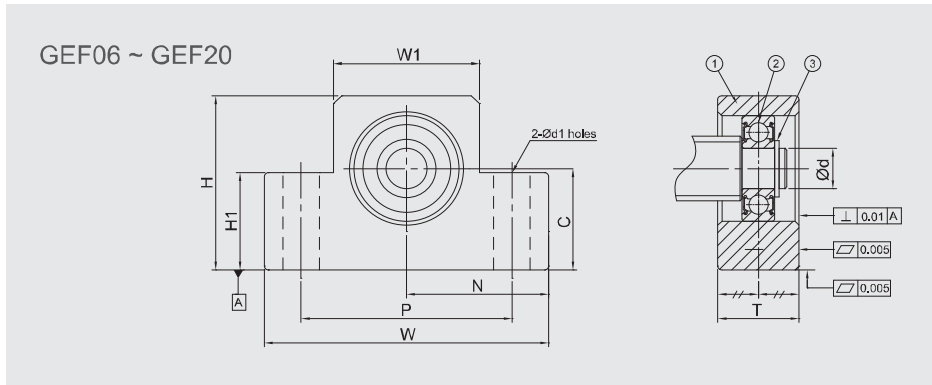

Specification

Standard Type	Dimensions							
	Ød	T	W <sub>0.04</sub>	W1	H	H1	P	Ød1
GEF06-S □	6	12	42	20	25	12	30	5.2
GEF08-S □	6	14	52	27	32	16	38	6.3
GEF10-S □	8	20	70	36	43	24	52	9
GEF12-S □	10	20	70	36	43	24	52	9
GEF15-S □	15	20	80	41	49	25	60	9
GEF20-S □	20	26	95	56	58	25	75	11

Ordering Example	GEF	10	S	N	J
	Model No.	Shaft Dia.	Grade	Surface finish	Bearing category



Components

No.	Parts	Material	Q'ty
①	Main housing	S50C	1
②	Bearing	SUJ2	1
③	Snap ring	SWB	1

- Bearing filled with proper lithium soap lubricant maintenance free.
- Bearing with two steel covers in black dyed.
- Bearing with two touch-type plastic covers in Ni-plating.

Recommended processing dimensions of shaft

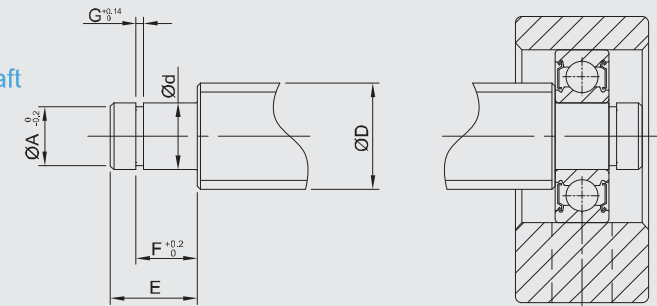

Unit : mm

N ±0.02	C <sub>0.04</sub>	Recommended processing dimensions of shaft						Snap ring
		Ball Screw Shaft O. D.	Shaft End Diameter	Groove sizes machined for snap ring				
		ØD	Ød	ØA	E	F	G	
21	13	8	6 <sup>-0.005</sup> <sub>-0.012</sub>	5.7	9	6.8	0.8	S 06
26	17	10	6 <sup>-0.005</sup> <sub>-0.012</sub>	5.7	9	6.8	0.8	S 06
35	25	12 / 14 / 15	8 <sup>-0.005</sup> <sub>-0.012</sub>	7.6	10	7.9	0.9	S 08
35	25	14 / 15 / 16	10 <sup>-0.005</sup> <sub>-0.012</sub>	9.6	11	9.15	1.15	S 10
40	30	18 / 20	15 <sup>-0.005</sup> <sub>-0.014</sub>	14.3	13	10.15	1.15	S 15
47.5	30	25 / 28 / 30	20 <sup>-0.005</sup> <sub>-0.014</sub>	19	19	15.35	1.35	S 20

• Fixed Side spec please refer to P.18~P.19 and P.26~P.27