



## X-Carriage guide



This work is licensed under a [GNU General Public License v3.0](https://www.gnu.org/licenses/gpl-3.0.html)

# Table of Contents

Introduction	1
Prusa	2
Version: X-Carriage_MK3(R2)	2
Bondtech	3
Version: X-Carriage_Modded(R2)_for_Mk2(s)	3
Bear	4
Version: Bondtech_x_carriage_mk3	4
Zaribo	5
Version: X-Carriage 2.31	5
Vecko	6
Version: X-Carriage v2	6
Version: X-Carriage v2.6S_Mk3	7
Version: X-Carriage v2.61S_Mk2s	8

## Introduction

This simple guide to show what fasteners you will need for some of the most popular X-Carriages. The Bondtech kit contains screws suited for the Original Prusa carriage, if you use another carriage different screw lengths and nuts could be necessary.

# Prusa

<https://github.com/prusa3d>

Version: X-Carriage\_MK3(R2)

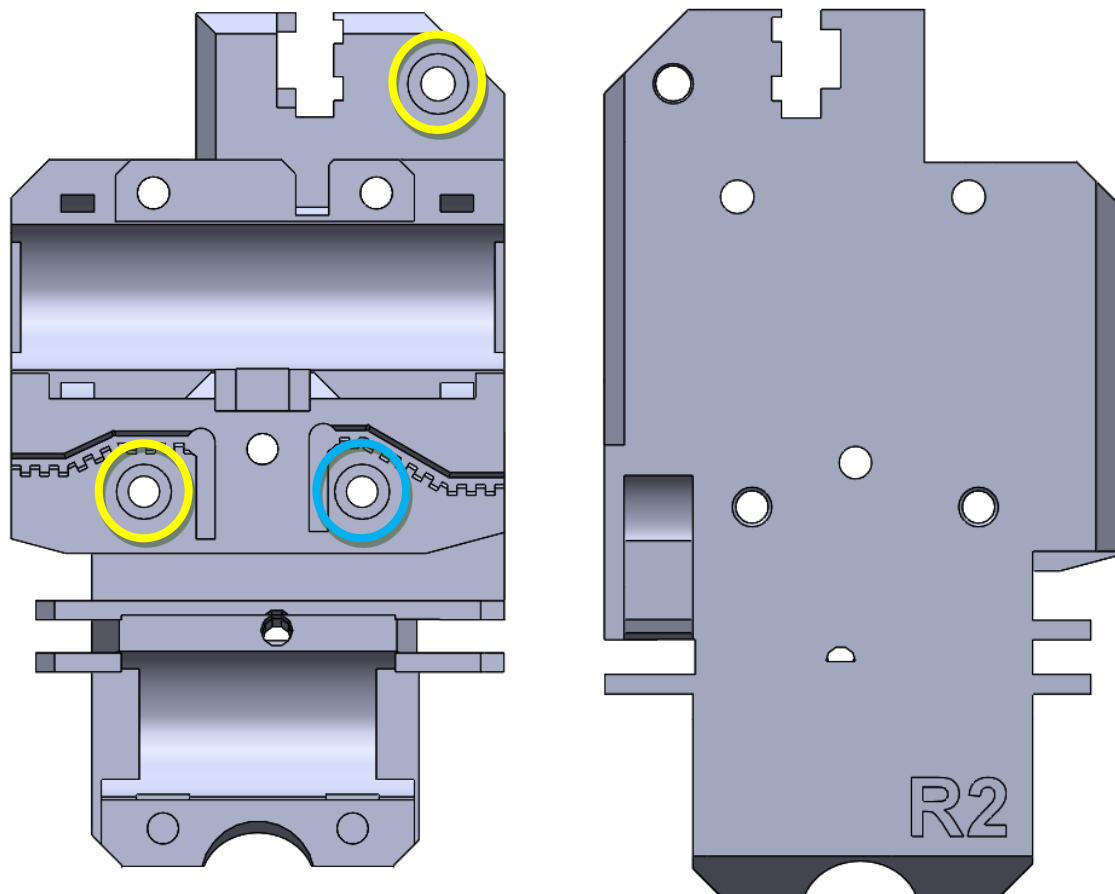

- M3x40
- M3x45

# Bondtech

[https://github.com/BondtechAB/Bondtech\\_Prusa\\_i3](https://github.com/BondtechAB/Bondtech_Prusa_i3)

Version: X-Carriage\_Modded(R2)\_for\_Mk2(s)

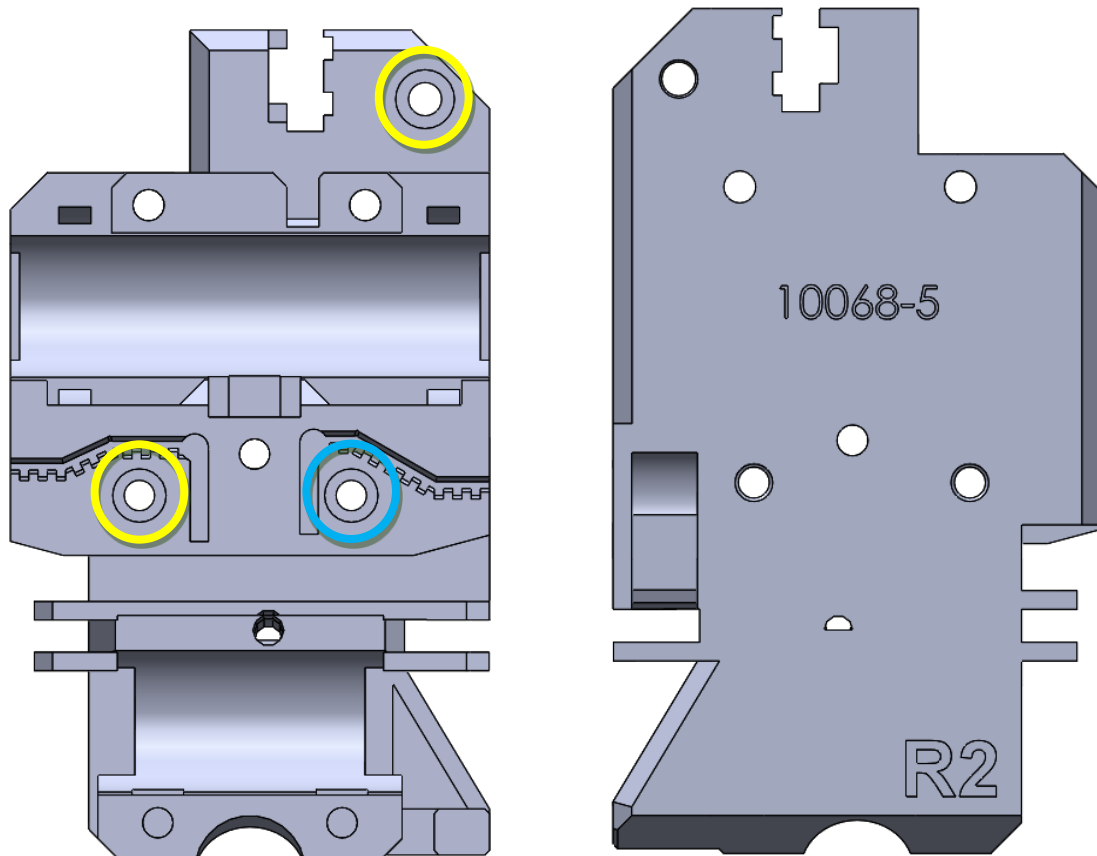

- M3x40
- M3x45

## Bear

[https://github.com/gregsaun/bear\\_extruder\\_and\\_x\\_axis](https://github.com/gregsaun/bear_extruder_and_x_axis)

<https://www.thingiverse.com/pekcitron/designs>

Version: Bondtech\_x\_carriage\_mk3

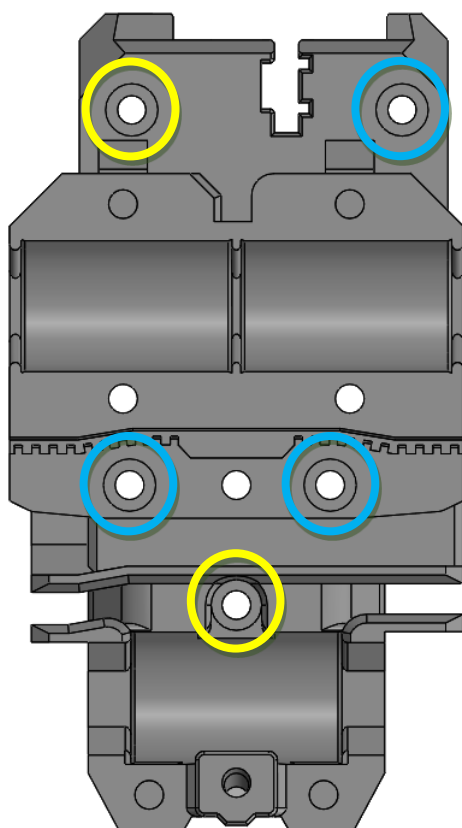

- M3x10 x2
- M3x40 x3

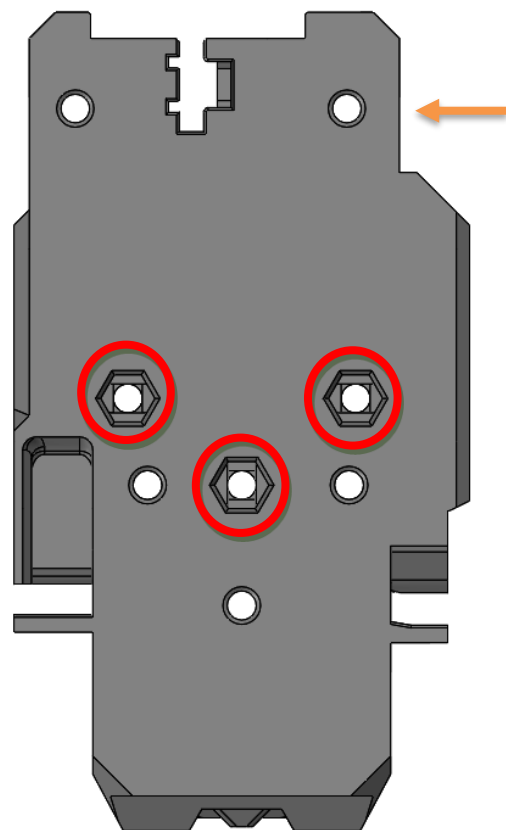

- M3 hex nut x3
- M3 Square nut (Into extruder)

# Zaribo

<https://github.com/Zaribo/Zaribo-MK3>

<https://www.thingiverse.com/wshadow/designs>

Version: X-Carriage 2.31

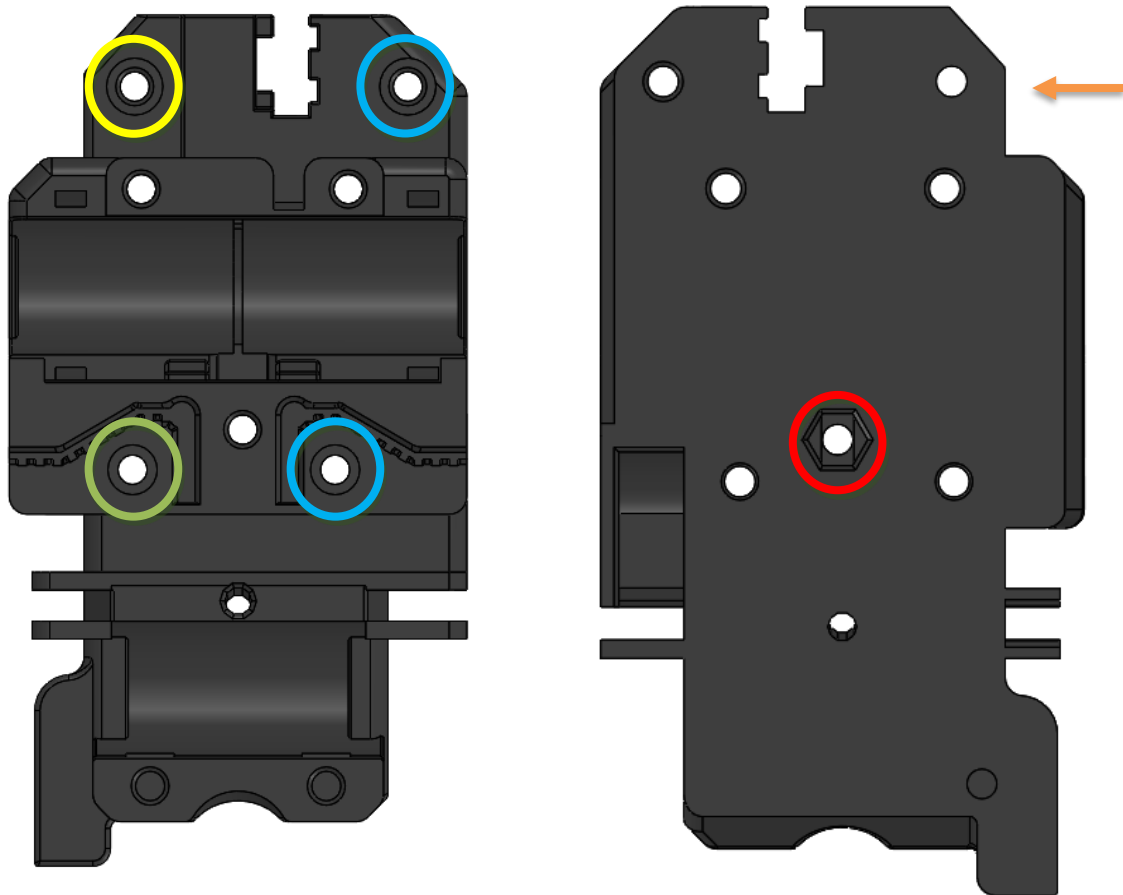

- M3x10
- M3x30
- M3x40 x2

- M3 hex nut.
- M3 Square (Into extruder)

# Vecko

<https://www.thingiverse.com/vekoj/designs>

Version: X-Carriage v2

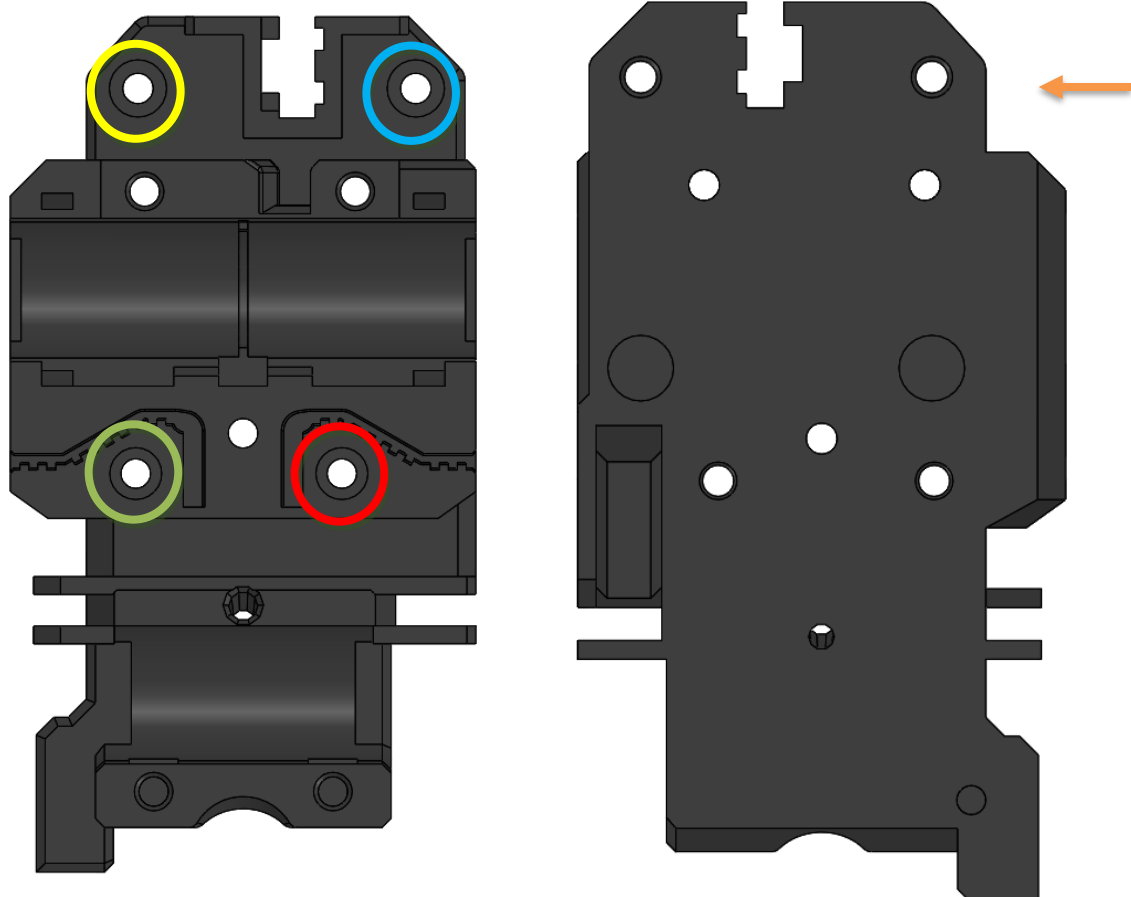

- M3x8
- M3x30
- M3x35
- M3x40

- M3 Square nut (Into extruder)

Version: X-Carriage v2.6S\_Mk3

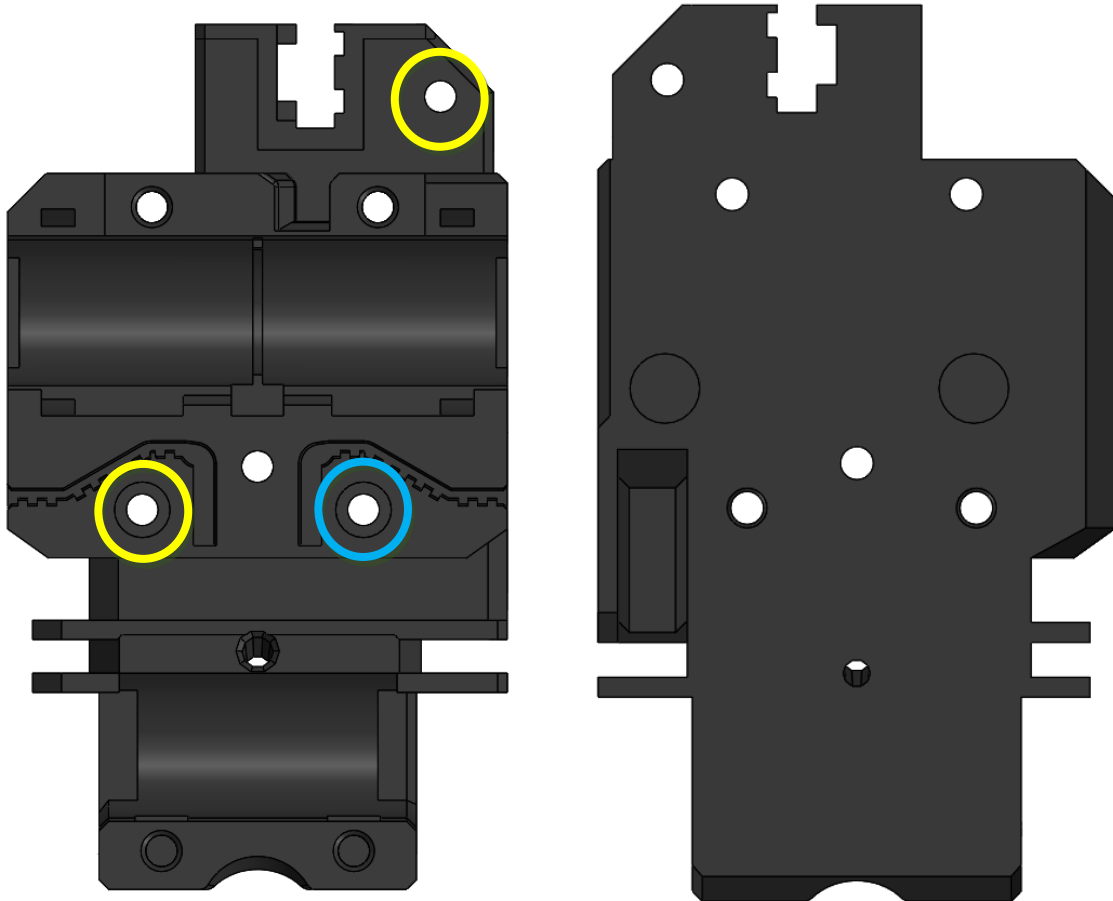

- M3x40
- M3x45



Version: X-Carriage v2.61S\_Mk2s

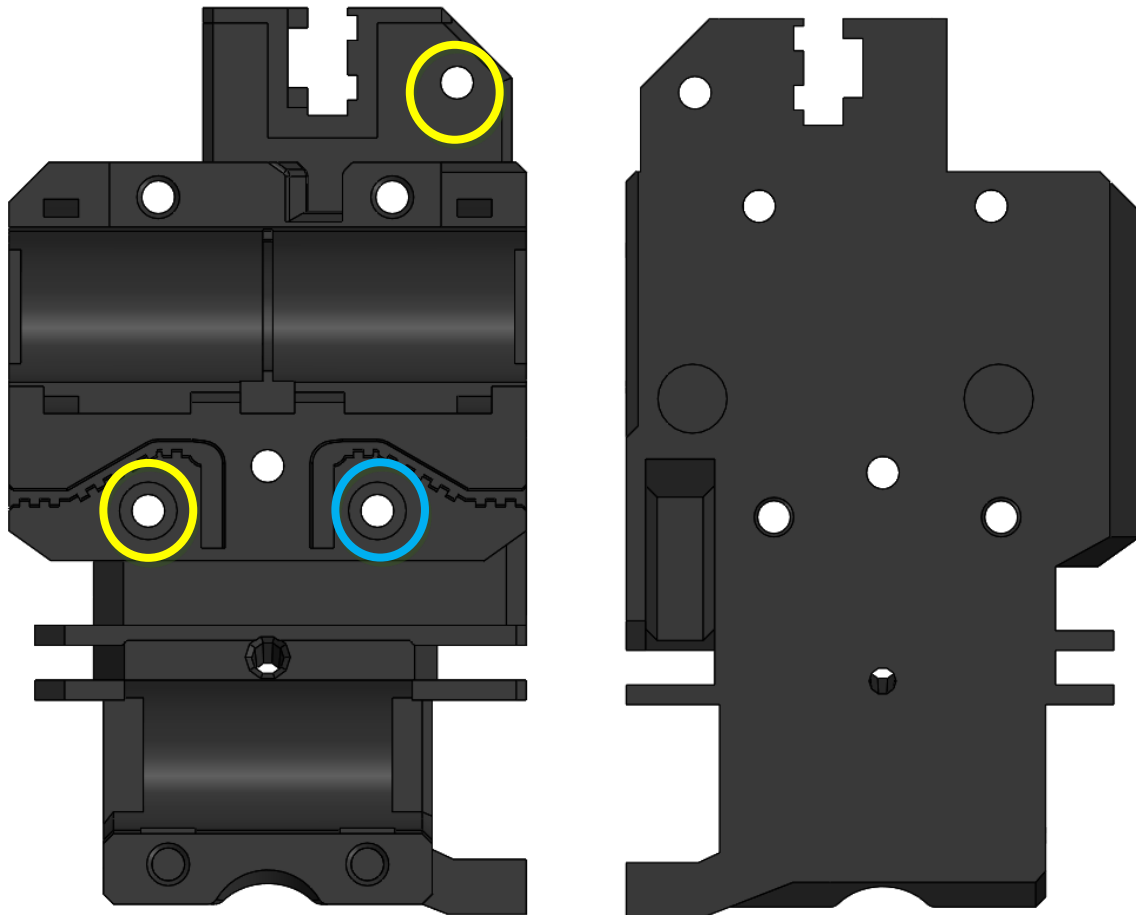

- M3x40
- M3x45

If you have any questions please first read the FAQ (<http://www.bondtech.se/en/faq/>). If the question still hasn't been answered feel free to contact us by email or our online chat.



Repslagarvägen 3 J  
33153 Värnamo  
Sweden

e-mail: [support@bondtech.se](mailto:support@bondtech.se)

phone: +46702220193

paypal: [payments@bondtech.se](mailto:payments@bondtech.se)

web: [www.bondtech.se](http://www.bondtech.se)

VAT-registration number: SE556995564301