

## Raise3D DualDirect

This compact, lightweight extruder upgrade for Raise3D printers (N1, N2, N2+) will solve your feeding problems, improves surface quality and make it possible to print with faster speeds with sustained quality.

This product uses lightweight Nema17 Pancake stepper motors combined with a 3:1 internal gearing ratio and our proven DualDrive gears. The body parts are manufactured with SLS printing in high strength polyamide (nylon). Drive gears are precision CNC-machined in hardened steel for maximum performance and lifetime.



## Technical Specification

- EAN-code 7350011412150
- Net weight 455g
- Gross weight 542g
- Package dimension 137x94x65mm
- Max current 0.7A
- Gearing ratio 3:1
- Filament diameter 1.75mm
- Operating temperature 0–80°C
- E-steps value 415

## Drawing

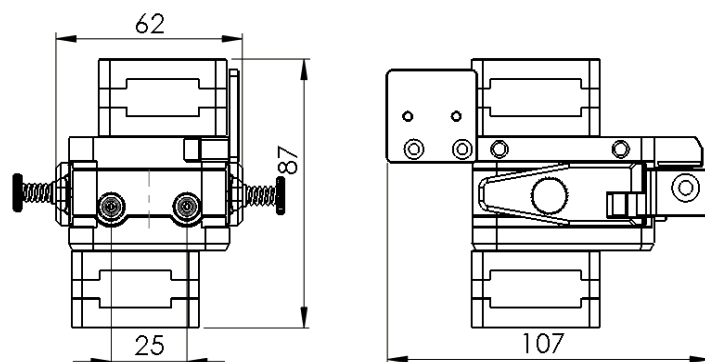

## Electrical Connection

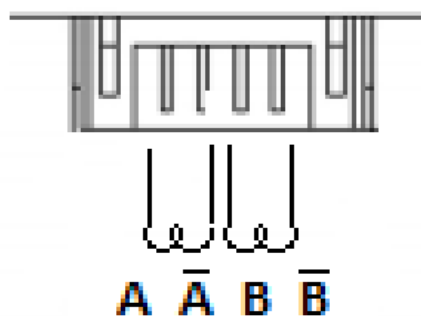

## Contact Information

Bondtech AB  
Repslagarevägen 3J  
33153 Värnamo  
Sweden

E-mail: [support@bondtech.se](mailto:support@bondtech.se)  
Web: [www.bondtech.se](http://www.bondtech.se)